

REFRIGERATOR MANUFACTURER
Turbo air
 more durable, efficient, beautiful

4184 E. Conant St.
 Long Beach, CA 90808
 Tel. 310-900-1000
 Fax. 310-900-1077
www.turboairinc.com

Project :	
Model # :	
Item # :	Qty :
Available W/H :	
Approval :	

Chef Bases (Extended Top)

*Chef Bases
 Super Deluxe Series*

Patented Self-Cleaning Condenser



This product is equipped with a fine mesh filter to the front of the condenser to catch dust, and a rotating brush that moves up and down daily to remove excess buildup outward and away.

**Model : TCBE-48SDR
 TCBE-48SDR-E**



TCBE-48SDR-E †

TCBE-48SDR

- Each drawer accommodates up to 4" deep sixth (1/6) size pans (drawer pans not included)

≡ FEATURES & BENEFITS ≡

■ **Maintenance-free, Self-Cleaning Condenser (patented) Only at Turbo Air**

The accumulation of dust in the condenser causes the failure or breakdown of refrigerators. Refrigerators run normally until they reach a certain level of accumulation. At some point, when they are over the limit, their performance drops quickly resulting in damage to, or disposal of the stored products in refrigerators. The self-cleaning condenser device keeps the condenser clean and prevents system failure by automatically brushing daily.

■ **Strong body and durable construction**

Built with heavy duty 16 gauges stainless steel Chef Base top is manufactured of one-piece reinforced stainless steel to ensure durability.

■ **Top is insulated to eliminate heat transfer to the interior of cabinet**

■ **Durable stainless steel drawers**

■ **Efficient refrigeration system**

Turbo Air's solid door refrigerators are designed with oversized and balanced (CFC Free R-134A) refrigeration systems. These include efficient evaporators and condensers for faster cooling and greater efficiency.

■ **Side mount compressor unit**

By positioning the compressor on the side of the unit, refrigerators can now be serviced without being moved. Our innovative, front breathing feature also allows this model to provide high efficiency in narrow spaces.

■ **High-density polyurethane insulation**

The entire cabinet structure and solid doors are foamed-in-place using high density, CFC free polyurethane insulation.

■ **Refrigerator holds 33°F ~ 38°F for the best in food preservation**



Model	Drawers	CU./FT.	Countertop Weight Capacity (lbs.)	HP	AMPS	Crated Weight (lbs.)	L x D x H* (inches)
TCBE-48SDR	2	6.1	788	1/4	3	284	47 5/8 x 32 x 20 1/2
TCBE-48SDR-E †	2	6.1	788	1/4	3	306	53 5/8 x 32 x 20 1/2

ELECTRICAL DATA	TCBE-48SDR	TCBE-48SDR-E†
Voltage	115/60/1	115/60/1
Plug Type	Ⓢ NEMA 5-15P	Ⓢ NEMA 5-15P
Full Load Amperes	3	3
Compressor HP	1/4	1/4
Cord Length (ft.)	9	9
Refrigerant	R-134A	R-134A
DIMENSIONAL DATA		
Ext. Length Overall (in.)	47 ⁵ / ₈ (1209mm)	53 ⁵ / ₈ (1361mm)
Ext. Depth Overall (in.)	32 (813mm)	32 (813mm)
Ext. Height Overall (in.)*	20 ¹ / ₂ (521mm)	20 ¹ / ₂ (521mm)
# of Drawers	2	2
# of Pans	30	30
Net Capacity (cu. ft.)	6.1	6.1
Net Weight (lbs.)	218	240
Gross Weight (lbs.)	284	306

Design and specifications subject to change without notice.

Actual shipping weight may differ due to extra packing materials for product protection.

* Height does not include 6" for caster height.

† Optional extended top available at **additional \$250 (net) Price to dealer net.**

■ **WARRANTY : 3 Year Parts and Labor Warranty
Additional 2 Year Warranty on Compressor**

- **Self-contained system**
- **5" dia. swivel casters standard**
- **Legs available (optional)**

■ **OPTIONAL ACCESSORIES :**

- 6" stainless steel leg: 30221M0600

PLAN VIEW

(unit : inch)

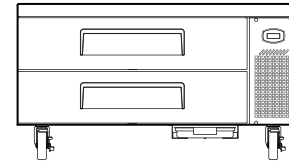

FRONT VIEW

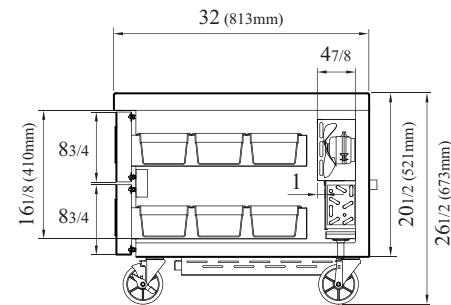

SIDE VIEW

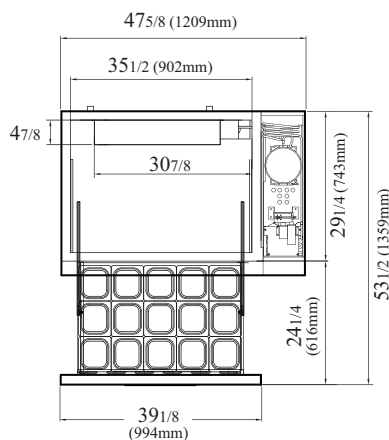

PLAN VIEW

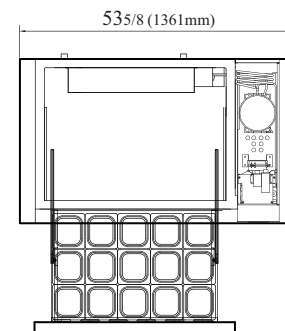

EXTENDED TOP PLAN VIEW

Ver.201701



- Turbo Air : 800-627-0032
- GK : 800-500-3519
- Warranty : 800-381-7770
- AC : 888-900-1002

