

**REFRIGERATOR MANUFACTURER**  
**Turbo air**  
 more durable, efficient, beautiful

4184 E. Conant St.  
 Long Beach, CA 90808  
 Tel. 310-900-1000  
 Fax. 310-900-1077  
[www.turboairinc.com](http://www.turboairinc.com)

Project :	
Model # :	
Item # :	Qty :
Available W/H :	
Approval :	

## Chef Bases (Extended Top)

*Chef Bases  
 Super Deluxe Series*

**Model : TCBE-96SDR**



TCBE-96SDR

- Each drawer accommodates up to 4" deep sixth (1/6) size pans (drawer pans not included)

**Self-Cleaning  
 Condenser**



**NO MAINTENANCE REQUIRED**

### ≡ FEATURES & BENEFITS ≡

- **Self-cleaning condenser device** Only at Turbo Air  
 The accumulation of dust in the condenser causes the failure or breakdown of refrigerators. Refrigerators run normally until they reach a certain level of accumulation. At some point, when they are over the limit, their performance drops quickly resulting in damage to, or disposal of the stored products in refrigerators. The self-cleaning condenser device keeps the condenser clean and prevents system failure by automatically brushing daily.
- **Strong body and durable construction**  
 Built with heavy duty 16 gauges stainless steel Chef Base top is manufactured of one-piece reinforced stainless steel to ensure durability.
- **Top is insulated to eliminate heat transfer to the interior of cabinet**
- **Durable stainless steel drawers**
- **Efficient refrigeration system**  
 Turbo Air's solid door refrigerators are designed with oversized and balanced (CFC Free R-134A) refrigeration systems. These include efficient evaporators and condensers for faster cooling and greater efficiency.
- **Side mount compressor unit**  
 By positioning the compressor on the side of the unit, refrigerators can now be serviced without being moved. Our innovative, front breathing feature also allows this model to provide high efficiency in narrow spaces.
- **High-density polyurethane insulation**  
 The entire cabinet structure and solid doors are foamed-in-place using high density, CFC free polyurethane insulation.
- **Refrigerator holds 33°F ~ 38°F for the best in food preservation**



Model	Drawers	CU./FT.	Countertop Weight Capacity (lbs.)	HP	AMPS	Crated Weight (lbs.)	L x D x H* (inches)
TCBE-96SDR	4	23	1435	1/4	6.3	517	963/8 x 32 x 20 1/2

ELECTRICAL DATA	TCBE-96SDR
Voltage	115/60/1
Plug Type	Ⓢ NEMA 5-15P
Full Load Amperes	6.3
Compressor HP	1/4
Cord Length (ft.)	9
Refrigerant	R-134A
DIMENSIONAL DATA	
Ext. Length Overall (in.)	96 <sup>3</sup> / <sub>8</sub> (2449mm)
Ext. Depth Overall (in.)	32 (813mm)
Ext. Height Overall (in.)*	20 <sup>1</sup> / <sub>2</sub> (521mm)
# of Drawers	4
# of Pans	72
Net Capacity (cu. ft.)	23
Net Weight (lbs.)	484
Gross Weight (lbs.)	517

Design and specifications subject to change without notice.  
Actual shipping weight may differ due to extra packing materials for product protection.  
\* Height does not include 6" for caster height.

■ **WARRANTY : 3 Year Parts and Labor Warranty**  
**Additional 2 Year Warranty on Compressor**

- **Self-contained system**
- **5" dia. swivel casters standard**
- **Legs available (optional)**

■ **OPTIONAL ACCESSORIES :**

- 6" stainless steel leg: 30221M0600

## PLAN VIEW

(unit : inch)

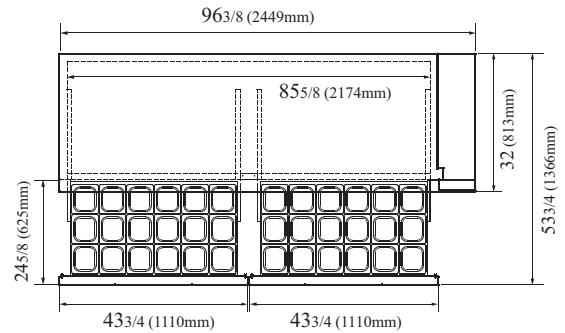

PLAN VIEW

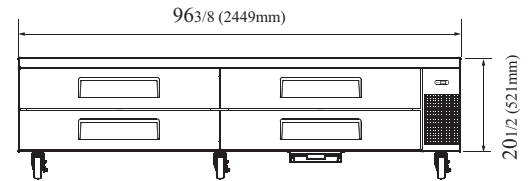

FRONT VIEW

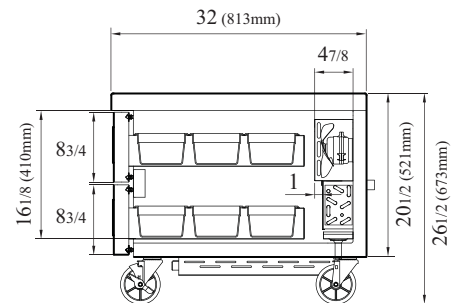

SIDE VIEW

Ver.201601



- Turbo Air : 800-627-0032
- GK : 800-500-3519
- Warranty : 800-381-7770
- AC : 888-900-1002