





Assembly Instructions

MUSTANG BACKREST BAR STOOL

PLEASE READ THESE ASSEMBLY INSTRUCTIONS CAREFULLY.

Actual Size Match up hardware with diagrams shown below

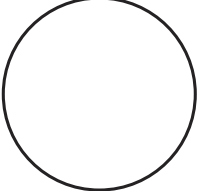
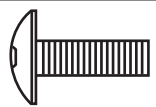
Hardware List

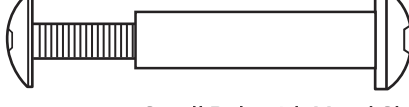
Description and Size	Qty
 <p>Metal Disc used for adjusting the balance on stool legs</p>	6
 <p>Small Bolt</p>	2
 <p>Medium Bolt</p>	4
 <p>Large Bolt w/lock nut</p>	4
 <p>Small Bolt with Metal Sleeve</p>	4

Parts List

Qty	Description and Size
1	Thick Foam Padded Seat
1	Thick Foam Padded Backrest
1	Swivel (with top & bottom offset)
1	Chrome Plated TOP leg with Glides
1	Chrome Plated BOTTOM leg with Glides
1	Large Chrome Plated Rings
2	Allen Keys
1	Wrench

WARRANTY:

Free replacement of any part that fails within one year from date of purchase, excluding shipping costs. Void if damaged by misuse, accidents, alterations, failure to follow instructions, fire, flood, and acts of God.

If you have any questions or comments, please contact us at:
BrandedProducts.com



Step 1: Place the two bar stool legs together as shown in the photo.



Step 2: Slide the ring over the legs and align the holes. Insert metal sleeve and secure with small bolt. Tighten all bolts securely.



Step 3: Place swivel on top of legs and align holes. Insert large bolts and screw on lock nuts securely.



Step 4: Turn the bar stool over and secure the seat to the swivel with medium bolts as shown in the picture.



Step 5: Slide the backrest into the tubes and secure with small bolts. Double check all nuts and bolts for tightness.

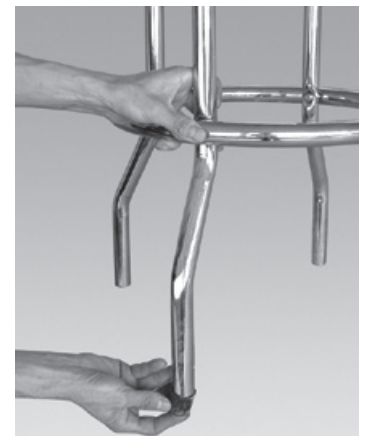

Step 6: For proper leveling, remove rubber cap and insert supplied metal discs, as needed.



Ford Motor Company trademarks and trade dress used under license to Ace Product Management Group, Inc. fordmotorcompany.com

Ace Product Management Group, Inc.
 Milwaukee, WI U.S.A.