





# H-D® 1-RING BAR STOOL

## Assembly Instructions

### Hardware List

#### Actual Size

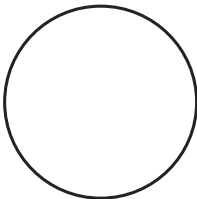
Match up hardware with diagrams shown below

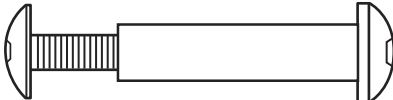
Description and Size	Qty
 <p>Metal Disc used for adjusting the balance on stool legs</p>	<b>6</b>
 <p>Medium Bolt</p>	<b>4</b>
 <p>Large Bolt w/lock nut</p>	<b>4</b>
 <p>Small Bolt with Metal Sleeve</p>	<b>4</b>

Congratulations on your purchase of a Harley-Davidson® Bar Stool. The utmost care has gone into the design and manufacturing of this product.

**PLEASE READ THESE Assembly INSTRUCTIONS CAREFULLY.**

### Parts List

Qty	Description and Size
<b>1</b>	Thick Foam Padded Seat
<b>1</b>	Swivel (with top & bottom offset)
<b>1</b>	Chrome Plated TOP Leg with Glides
<b>1</b>	Chrome Plated BOTTOM Leg with Glides
<b>1</b>	Large Chrome Plated Ring
<b>2</b>	Allen Keys
<b>1</b>	Wrench



**Step 1:** Place the two bar stool legs together as shown in the photo.



**Step 2:** Slide the ring over the legs and align the holes. Insert metal sleeve and secure with small bolt. Tighten all bolts securely.

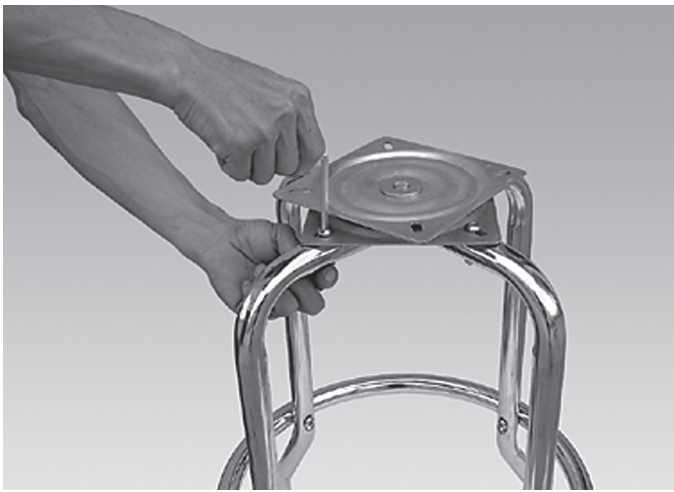

**Step 3:** Place swivel on top of legs and align holes. Insert large bolts and screw on lock nuts securely.



**Step 4:** Turn the bar stool over and secure the seat to the swivel with medium bolts as shown in the picture.



**Step 5:** Double check all nuts and bolts for tightness.

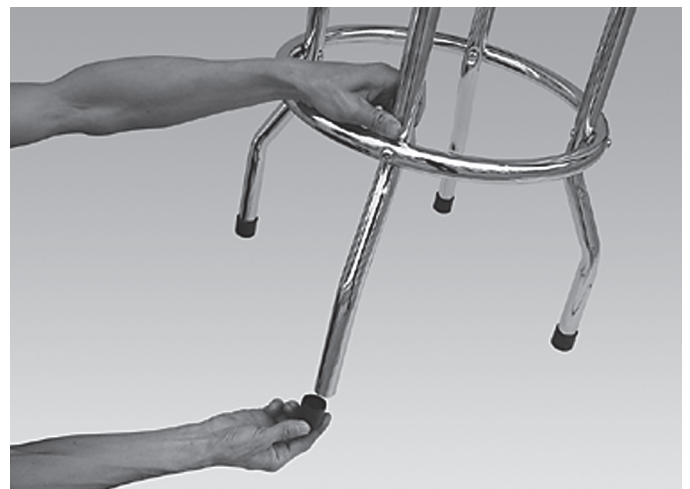

**Step 6:** For proper leveling, remove rubber cap and insert supplied metal discs, as needed.

## Warranty:

Free replacement of any part that fails within one year from date of purchase, excluding shipping costs. Void if damaged by misuse, accidents, alterations, failure to follow instructions, fire, flood, and acts of God.

If you have any questions or comments, please contact us at:

**BrandedProducts.com**



For a dealer near you call toll free 1-800-588-2743 in the USA and Canada or use our dealer locator at [www.harley-davidson.com](http://www.harley-davidson.com)

Ace Product Management Group, Inc. Milwaukee, WI U.S.A. Manufactured under license from Harley-Davidson Motor Co. © 2009 All Rights Reserved.

Ace Product Management Group, Inc.  
Milwaukee, WI U.S.A.