

T2 Piston Cover Kit

333497A

EN

For use with polyurethane foam, polyurea, and similar non-flammable materials. For professional use only. Not for use in explosive atmospheres.

Part No. 24V858



Important Safety Instructions

Read all warnings and instructions in pump manual 311882. Save these instructions.

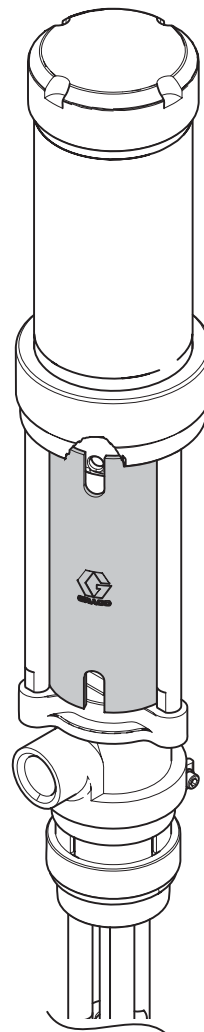

ti23682a

Installation

1. Remove the air cylinder assembly (A). Unscrew by hand or use a strap wrench to prevent the cylinder from distorting.

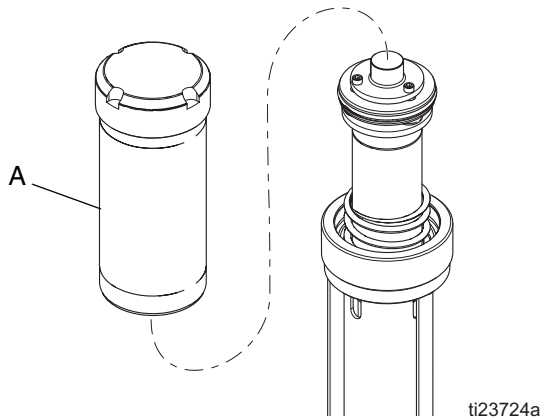

NOTE: Series A motors have thin, flat, white seals in the air valve. Series B air motors have thicker black seals in the air valve.

2. **Series A air motors only:** Loosen set screw (18) and unscrew air valve (5). If necessary to assist turning, wedge a screwdriver blade between the screw heads and the hex cap of air valve (5).

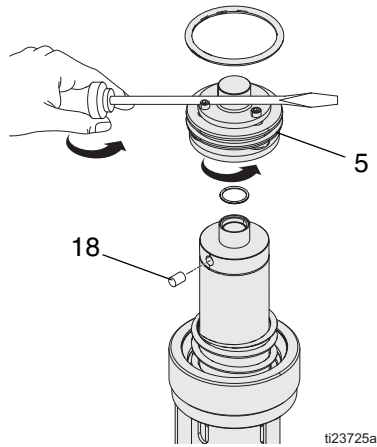

3. **Series B and later T2 pumps:** Unscrew air valve (5). If necessary to assist turning, wedge a screwdriver blade between the screw heads and the hex cap of the air valve (5).

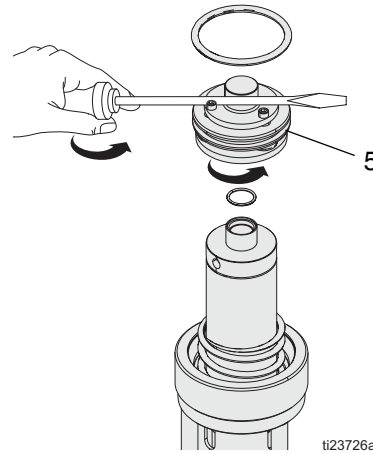

4. Remove three cap screws (60) from flange base (26). **NOTE:** If necessary, rotate the flange counter-clockwise slightly to access all cap screw heads. Tighten the flange (26) after reassembling the screws.

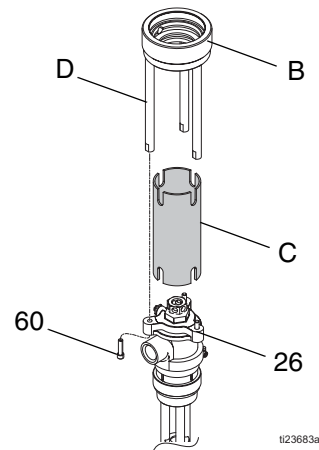

5. Remove Air Motor Base/Tie Rod assembly (B). Leave the Air Piston assembled with the transfer shaft.
6. Slide the piston cover (C) in between the tie rods (D) and reassemble in reverse order.

All written and visual data contained in this document reflects the latest product information available at the time of publication. Graco reserves the right to make changes at any time without notice.

Original instructions. This manual contains English. MM 333497
Graco Headquarters: Minneapolis

International Offices: Belgium, China, Japan, Korea

GRACO INC. AND SUBSIDIARIES • P.O. BOX 1441 • MINNEAPOLIS MN 55440-1441 • USA
Copyright 2014, Graco Inc. All Graco manufacturing locations are registered to ISO 9001.

www.graco.com
Revision A - 2014