

D SERIES PLATFORM CART

Designed to Accommodate Various Tanks!

Getting oil from bulk or drum storage and out into the plant is made convenient and easy with the PT-D Platform Cart. Designed to accommodate various tank configurations, the platform cart can be used to deliver multiple oil types to their final destination. An optional oil rack and toolbox makes storage of essential equipment and tools easy to transport. The platform cart has all the power needed for filtering oil viscosities up to 600cSt (ISO VG 680) at 100F within ambient temperature ranges of -15F to 150F. All Y2K products are 100% customizable upon request.



Typical Applications

- Pre-filtering new oil
- Transferring oils
- Topping off reservoirs or containers
- Dispensing new oil
- Waste oil extraction

ForFluids.com

D SERIES PLATFORM CART

Don't see the options you need?
Contact For Fluids at 1(630) 922-5020
for more information.

Performance:

For filtering mineral and synthetic based oils (hydraulic oils, gear oils and turbine oils). This powerhouse has the ability to filter oil viscosities up to 600cSt (ISO VG 680) at 100F within ambient temperature ranges of -15F to 150F.

Standard Features:

Materials:

- Frame: Carbon steel platform frame with drip pan & utility tray
- Paint: Multiple color options available
- Tank(s): 32, 71 and 115 gallon poly tanks available
- Motor: 1HP, 115vac, 60Hz or Pneumatic
- Filter Heads: Medium pressure, cast aluminum heads
- Pump: Heavy duty, cast steel gear pump. Available in 1, 2, 5 and 10 GPM
- Connections: Various quick connect options available
- Hoses: 7ft. Clear PVC, steel reinforced hose or hydraulic hose
- Power Switch: Sealed On/Off Power Switch

Filter Indicators:

- Slide bar indicator triggers at 50psid when elements need to be changed.

Pump Relief:

- Opens at 150psi

Weight:

- Approx. 250lbs (will vary depending on options)

Dimensions:

- Approx. 55"L x 24"W x 52"H (dual tank, dual elements)

Replacement Elements:

Part Number	BETA Rating	Desired Cleanliness Level (ISO Code)
P1066	$\beta_{4(c)}=2000$	14/12/9 - 13/11/8
P1065	$\beta_{7(c)}=2000$	18/16/13 - 15/13/10
P1063	$\beta_{10(c)}=1000$	19/17/14 - 18/16/13
P1064	$\beta_{25(c)}=2000$	20/18/15 - 19/17/14
P1048WR	Water Removal	

All D Series elements measure 5" x 14".

Components:

Item Number	Description	Qty.
1	Heavy Duty Cart	1
2	Tank	1
3	Motor	1
4	Pump	1
5	Filter Head	2
6	Filter Element	2
7	Filter Indicator	2
8	Switch On/Off	1
9	Sample Port	2
10	Breather Adapter	1
11	Breather	1
12	Cord Reel	1
13	Parking Brake	1

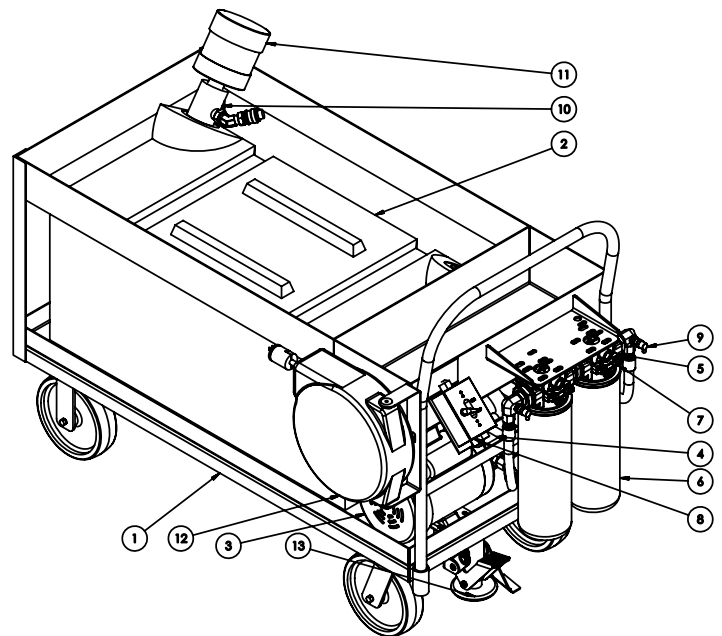

ForFluids.com

M SERIES PLATFORM CART

Designed to Accommodate Various Tanks!

Getting oil from bulk or drum storage and out into the plant is made convenient and easy with the PT-M Platform Cart. Designed to accommodate various tank configurations, the platform cart can be used to deliver multiple oil types to their final destination. An optional oil rack and toolbox makes storage of essential equipment and tools easy to transport. The platform cart has all the power needed for filtering oil viscosities up to 600cSt (ISO VG 680) at 100F within ambient temperature ranges of -15F to 150F. All Y2K products are 100% customizable upon request.



Typical Applications

- Pre-filtering new oil
- Transferring oils
- Topping off reservoirs or containers
- Dispensing new oil

ForFluids.com

M SERIES PLATFORM CART

Don't see the options you need?
Contact For Fluids at 1(630) 922-5020
for more information.

Performance:

For filtering mineral and synthetic based oils (hydraulic oils, gear oils and turbine oils). This powerhouse has the ability to filter oil viscosities up to 600cSt (ISO VG 680) at 100F within ambient temperature ranges of -15F to 150F.

Standard Features:

Materials:

- Frame: Carbon steel platform frame with drip pan & utility tray
- Paint: Multiple color options available
- Tank(s): 32, 71 and 115 gallon poly tanks available
- Motor: 1HP, 115vac, 60Hz or Pneumatic
- Filter Heads: Low pressure, aluminum heads
- Pump: Aluminum gear pump. Available in 2, 5 and 10 GPM
- Connections: Various quick connect options available
- Hoses: 7ft. Clear PVC, steel reinforced hose or hydraulic hose
- Power Switch: Sealed On/Off Power Switch

Filter Indicators:

- Pop up indicator triggers at 50psid when elements need to be changed.

Pump Relief:

- Opens at 150psi

Weight:

- Approx. 250lbs (will vary depending on options)

Dimensions:

- Approx. 55"L x 24"W x 52"H (dual tank, dual elements)

Replacement Elements:

Part Number	BETA Rating	Desired Cleanliness Level (ISO Code)
P1068	$\beta_{3(c)}=1000$	14/12/9 - 13/11/8
P1069	$\beta_{6(c)}=1000$	17/15/12 - 14/12/9
P1070	$\beta_{10(c)}=1000$	18/16/13 - 17/15/12
P1071	$\beta_{25(c)}=1000$	21/19/16 - 20/18/15
P1072WR	Water Removal	

All M Series elements measure 5" x 10".

Components:

Item Number	Description	Qty.
1	Heavy Duty Cart	1
2	Tank	1
3	Motor	1
4	Pump	1
5	Filter Head	2
6	Filter Element	2
7	Filter Indicator	2
8	Switch On/Off	1
9	Sample Port	2
10	Breather Adapter	1
11	Breather	1
12	Cord Wrap Area	1
13	Parking Brake	1

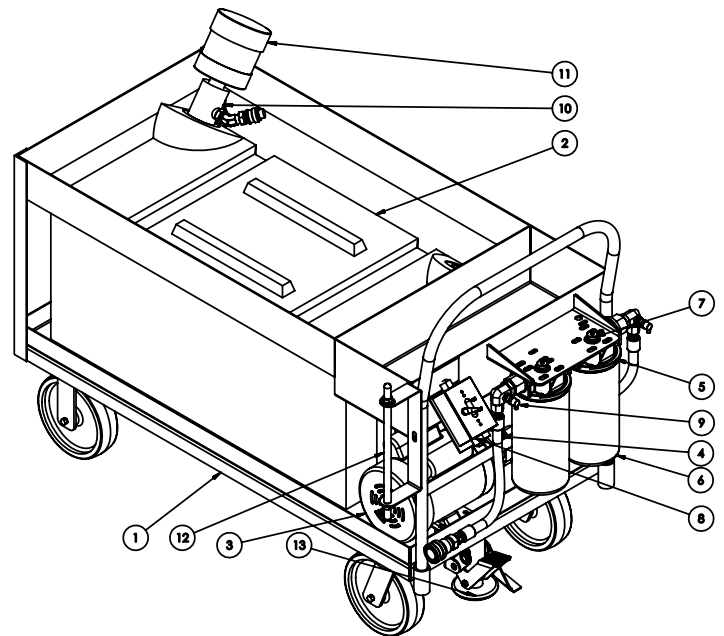

ForFluids.com