

D SERIES FILTER CART



Simple & Powerful!

The Y2K HT-D Series Filter Cart is our signature filter cart and is an excellent choice for “off-line” filtration in a wide variety of settings. Extremely mobile and lightweight, this filter cart has all the power needed for filtering oil viscosities up to 600cSt (ISO VG 680). This filter cart is completely customizable to fit all of your needs.

Typical Applications

- Filtering contaminated systems
- Flushing new or repaired systems
- Pre-filtering new oil
- Transferring oils
- Topping off reservoirs
- Collecting oil samples for analysis
- Dispensing new oil

ForFluids.com

D SERIES FILTER CART

Don't see the options you need?
Contact For Fluids at 1(630) 922-5020
for more information.

Performance:

For filtering mineral and synthetic based oils (hydraulic oils, gear oils and turbine oils) with a maximum operating viscosity range of ISO VG 680 (3000ssu/648cSt) at 100 °F within ambient temperature ranges of -15 °F to 150 °F.

Standard Features:

Materials:

- Frame: Carbon steel with drip pan
- Paint: Industrial powder coat; various colors available
- Motor: 1HP, 115vac, 60Hz or Pneumatic
- Filter Heads: Medium pressure, cast aluminum heads
- Pump: Heavy duty, cast steel gear pump. Available in 1, 2, 5 and 10 GPM
- Connections: Various quick connect options available
- Hoses: Clear PVC, steel reinforced hose or hydraulic hose
- Power Switch: Sealed on/off Power Switch

Filter Indicators:

- Slide bar indicator triggers at 50psid when elements need to be changed.

Pump Relief:

- Opens at 150psi

Weight:

- Approx. 125lbs (will vary depending on options)

Dimensions:

- Approx. 23"L x 22"W x 52"H

Replacement Elements:

Part Number	BETA Rating	Desired Cleanliness Level (ISO Code)
P1066	$\beta_{4(c)}=2000$	14/12/9 - 13/11/8
P1065	$\beta_{7(c)}=2000$	18/16/13 - 15/13/10
P1063	$\beta_{10(c)}=1000$	19/17/14 - 18/16/13
P1064	$\beta_{25(c)}=2000$	20/18/15 - 19/17/14
P1048WR	Water Removal	

All D Series elements measure 5" x 14".

Components:

Item Number	Description	Qty.
1	Frame	1
2	Motor	1
3	Pump	1
4	Filter Head	2
5	Filter Element	2
6	Filter Indicator	2
7	Switch On/Off	1
8	Sample Port	2
9	Cord Reel	1
10	Differential Gauge	1

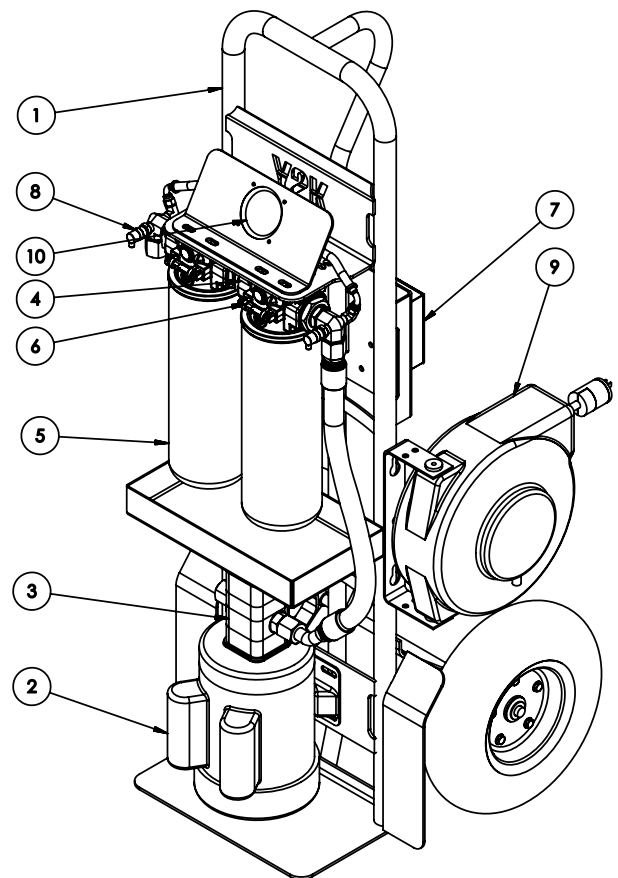

ForFluids.com

M SERIES FILTER CART



Simple & Powerful!

The HT-M Series filter cart is a great choice for “off-line” filtration in a wide variety of settings. Extremely mobile and light weight, this filter cart has the ability to filter oil viscosities up to 600cSt (ISO VG 680) at 100F within ambient temperature ranges of -15F to 150F. All Y2K products are 100% customizable upon request.

Typical Applications

- Filtering contaminated systems
- Flushing new or repaired systems
- Pre-filtering new oil
- Transferring oils
- Topping off reservoirs
- Collecting oil samples for analysis
- Dispensing new oil

ForFluids.com

M SERIES FILTER CART

Don't see the options you need?
Contact For Fluids at 1(630) 922-5020
for more information.

Performance:

For filtering mineral and synthetic based oils (hydraulic oils, gear oils and turbine oils) with a maximum operating viscosity range of ISO VG 680 (3000ssu/648cSt) at 100 °F within ambient temperature ranges of -15 °F to 150 °F.

Standard Features:

Materials:

- Frame: Carbon steel with drip pan
- Paint: Industrial powder coat; various colors available
- Motor: 1HP, 115vac, 60Hz or Pneumatic
- Filter Heads: Low pressure, aluminum heads
- Pump: Aluminum gear pump. Available in 2, 5 and 10 GPM
- Connections: Various quick connect options available
- Hoses: 7ft. Clear PVC, steel reinforced hose or hydraulic hose
- Power Switch: Sealed On/Off Power Switch

Filter Indicators:

- Pop up indicator triggers at 50psid when elements need to be changed.

Pump Relief:

- Opens at 150psi

Weight:

- Approx. 125lbs (will vary depending on options)

Dimensions:

- Approx. 23"L x 22"W x 52"H

Replacement Elements:

Part Number	BETA Rating	Desired Cleanliness Level (ISO Code)
P1068	$\beta_{3(c)}=1000$	14/12/9 - 13/11/8
P1069	$\beta_{6(c)}=1000$	17/15/12 - 14/12/9
P1070	$\beta_{10(c)}=1000$	18/16/13 - 17/15/12
P1071	$\beta_{25(c)}=1000$	21/19/16 - 20/18/15
P1072WR	Water Removal	

All M Series elements measure 5" x 10".

Components:

Item Number	Description	Qty.
1	Frame	1
2	Motor	1
3	Pump	1
4	Filter Head	2
5	Filter Element	2
6	Filter Indicator	2
7	Switch On/Off	1
8	Sample Port	2
9	Cord Wrap Area	1
10	Filter Bypass Valve	1

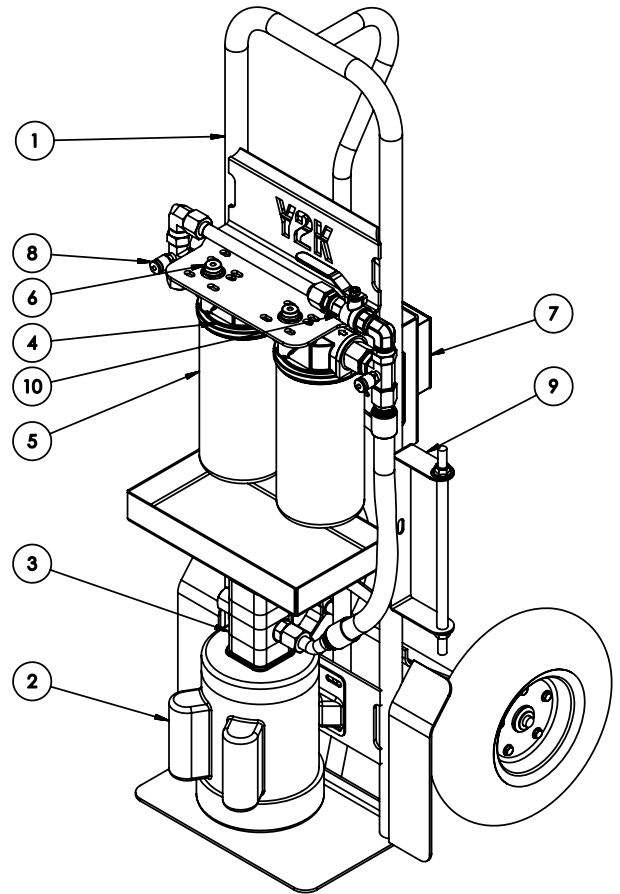

ForFluids.com